



COMPANY PROFILE WALZEN IRLE





1 *Top view to our machining facility (WALZEN IRLE Plant 1)*

2 *Top view to our foundry (WALZEN IRLE Plant 2)*

Continuous research has made WALZEN IRLE a world-leading company in roll technology for various industries.

MANAGING DIRECTORS

Dr.-Ing. Petrico von Schweinichen

Thomas Fink

EMPOYEEES

300 employees, thereof 18 trainees



OUR QUALITY HAS TRADITION

Rolls »made in Deuz« are used worldwide and have made a name for themselves for sophisticated technology and highest quality.

This standard is a commitment: technological perfection and permanently new developments have been our tradition - for over 195 years. The history of the company reaches far back into the 17th century. At that time the first generation of the Irlé family turned their interest toward iron and made the mining and processing of it their profession and ambition. In 1820 the first chilled cast iron rolls were produced by casting in chilled moulds, in 1884 the first rolls for the paper- and cardboard production were produced. IRLE also produced – according to their own patent – the worlds first centrifugal cast rolls.

Also due to personal ambition and entrepreneurial initiative of the following generations could the reputation and today's worldwide prestige be achieved.

A high performance company with international importance – that's what WALZEN IRLE GmbH is today.

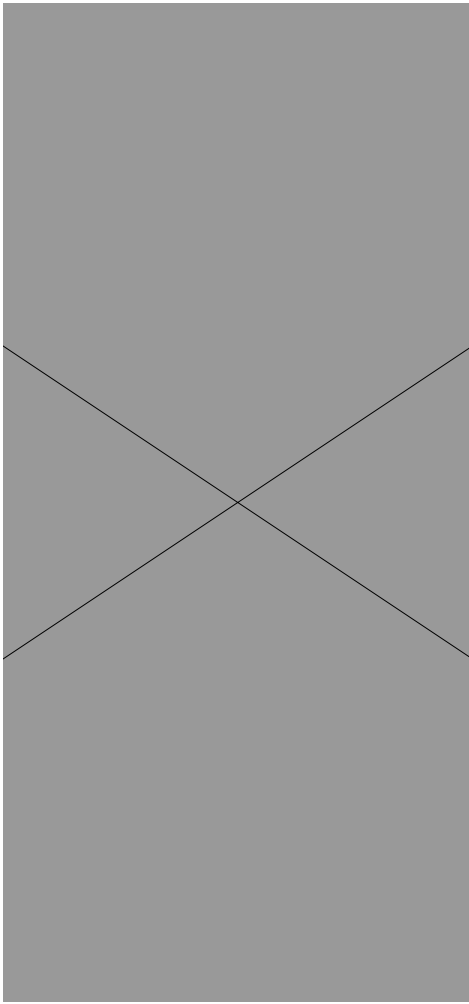

FOUNDRY

MELTING FACILITIES:

- 8 electrical furnaces (induction) from 3 to 30 tons

CASTING FACILITIES:

- static single poured and compound casts - single pieces up to a maximum cast weight of 130 tons, over a diameter of over 1,700 mm and 13 m length
- horizontal/vertical centrifugal cast machines for single poured and compound cast pieces up to a barrel length of 6 meters
- vertical spin casting machine for rolls up to 11,5 m length and 75 tons finish weight

HEAT TREATING FACILITIES:

- 17 gas-fired heat treatment furnaces



MECHANICAL PROCESSING

In twelve processing halls, modern production- and machining lines with over 80 mainly CNC-controlled machines have been installed.

Machining of cast parts in operation According to the products and their dimensions the manufacturing steps, turning, milling, boring, grinding, hardening, finishing, dynamic balancing and packing are efficiently installed. Specialized departments carry out the machining of fluidly heated thermal rolls. Special methods to guarantee the roll geometries under operating conditions are applied here. Seal testing to determine the pressure stability and warm balancing for optimal running properties of the rolls are carried out here.

Especially for plastic calender rolls a surface roughness of smaller $0.01 \mu\text{m}$ and a concentricity accuracy of $1 \mu\text{m}$ are achieved.

PRODUCTION CAPACITY:

- Average production per month about 1.500 tons finished work pieces

MAXIMUM ROLL SIZES:

- Barrel length: up to 13 m
- Diameter: up to 1,7 m
- Finish weight: up to 130 tons per workpiece

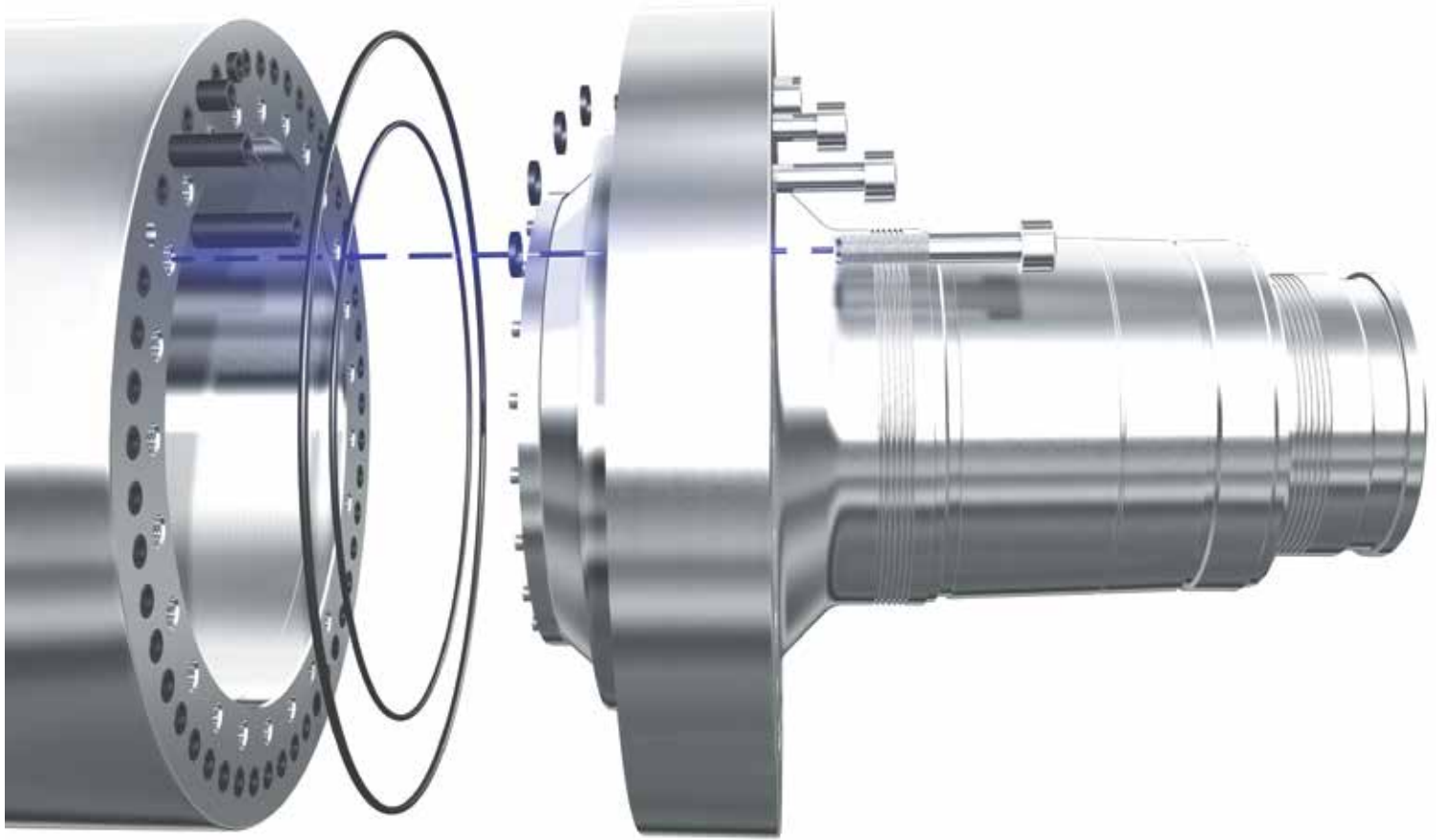

CONSTRUCTION

WALZEN IRLE has its own construction- and calculating department (amongst others, according to FEM-Methods of Finite Elements). Hereby customers are effectively supported as early as at the conception phase of a new installations and when modernising already installed steel roll mills.

Apart from the preparation of drawings- and order documents the following areas are also covered:

- on-going technical support of the customer regarding our products
- planning of the technical documents for our products
- research and development especially in the area of heated calender rolls in cooperation with the metallurgic laboratory.
- Patent monitoring

Technical consultation and constructional support

- technical sales support
- dimensioning of components according to customer demands
- load-carrying capacity of the components- and fatigue strength analysis
- optimising of the components according to the customer's requirements



QUALITY DEPARTMENT

The quality control mainly includes the process control and the individual testing of products. The manufacturing process moulded products is subject to a number of influencing factors whose interaction determines the quality of the products.

Main factors in the process are the precise chemical composition of the materials, the melting- and casting process within a tight temperature- and time frame, specific heat treatment- and hardening and tempering processes and the mechanical machining of the product.

The quality assurance of the production process includes the permanent control of the material by testing the chemical composition using a spectrometer, combustion analysis of carbon and sulphur and the gas analysis of the contents of oxygen and nitrogen as well as checking the mechanical properties and the metallography to ensure the correct formation of the microstructure of our defined materials.

The high qualification of our staff in combination with our experience enables us to realise tailor made solutions and customer specific improvements. We are continuously optimising our work process according to the ISO 9001:2015 Quality Management, the ISO 14001:2015 Environment Management and the ISO 50001:2018 Energy Management Systems.

PRODUCTS

ROLLS FOR HOT STRIP AND HEAVY STEEL PLATE

The main customers for flat steel products are construction-, plant/machine manufacturers-, household appliances-, ship builders-, railway vehicles-, commercial vehicles- and car industry. The last mentioned have the highest demands on the material properties and surface qualities of the steel sheets and bands.

We produce work rolls, backup rolls and edger rolls for hot strip, small strip mills, middle strip mills, wide strip mills, heavy-plate steel mills, heavy plate and sheet rolling mills.

ROLLS FOR THE PRODUCTION OF LONG PRODUCTS

IRLE Rolls for the steel industry are manufactured according to the most modern metallurgical and technical machining standards under the leadership of experienced engineers.

Using WALZEN IRLE profile rolls, long products such as roll wire, slabs, concrete steel, profiles and rails can be manufactured. We supply rolls for fine section mills, middle section mills, large section mills, tube rolling mills, wire rolling mills and bar rolling mills.



PRODUCTS

ROLLS FOR THE PAPER INDUSTRY

Since 1884 we have purposefully and continually developed our, in the meantime world-wide, leading knowledge in the areas of standard rolls and heated rolls for conventional calenders, soft calenders, super calenders and multinip calenders.

As evidence of our intensive efforts to effectively support our partners in the paper machine engineering and in the paper industry, we own more than 20 patents and innovations which we have developed in the calender roll sector.

We have at our disposal roll concepts for the complete production spectrum of the paper industry graphical paper, cardboard- and packaging paper, tissue paper and special paper.

ROLLS FOR THE RUBBER AND PLASTIC INDUSTRY

Calender rolls are a central success factor for a profitable production of strip and foil goods made of plastic and rubber mixtures. The production success of the whole plastic- and rubber production using rolling processes depends upon the perfect quality of these properties and last but not least the marketability of those plastic and rubber products.

IRLE rolls are used in the following rolling mills of the rubber and plastic industry: in crushing roll mills, refining mills and mixing mills, in reverse roll coaters and in calender roll mills.

ROLL SERVICE

WALZEN IRLE primary focuses on the roll service for calender rolls which are used in the paper and plastics industries. Through years of experience we understand the wear behavior of calender rolls and the repair and optimization options very carefully. We can optimize measurable the efficiency and productivity of existing plants.



PRODUCTS

ROLLS FOR THE FOOD INDUSTRY

The industrial production of food, particularly by roll processes as crushing, grinding, rubbing or flaking, place special demands on the rollers used. We supply rolls for: oil mills, flour milling / flour mills, crushers, flaker mills mixers, cocoa mills, and coffee mills. Our proprietary specialty materials for the food industry are ORT®, OCC®, OCE® and OCR®.

PISTONS FOR HEAVY HYDRAULIC PRESSES

We manufacture O.E.M. pistons in all sizes and various designs for all well known machine builders of heavy hydraulic presses.

We deliver solid cast pistons as well as hollow cast finish machined.

A special moulding procedure enable us to manufacture pistons with grey iron heads and chilled cast iron shafts. The low hardness of grey iron piston heads allows to machine grooves for piston rings very comfortable.

WEAR RESISTANT CASTINGS

Wear resistant castings are used in industries where wear is significant and cost-intensive. Our main customers are companies from the tile and brick, dredging, cement industry and coal power plants. WALZEN IRLE offers a wide range of basic materials and special qualities, and also has the possibility to optimize these application-related. All applications have one important property in common: high wear demands. This requires tools and components that are as resistant as possible under extreme wear demands.



IRLE DEUZ GmbH
Holding Company
www.irle-group.com

WALZEN IRLE GmbH
www.walzenirle.com

SIWACO GmbH
www.siwaco.com

IRLE KAY JAY ROLLS Pvt. Ltd.
www.ikjrolls.com

WALZEN IRLE GmbH
Huettenweg 5 · 57250 Netphen · Germany

phone +49 (0)2737 / 504-0
fax +49 (0)2737 / 504-111
email information@walzenirle.com
web www.walzenirle.com



A Member of the
IRLE GROUP